

ELM & ELM2 EMERGENCY LIGHTING RECALL INSPECTION & CIRCUIT BOARD REPLACEMENT INSTRUCTIONS

CAUTION: Read and follow Important Safeguards carefully before proceeding.



Patent # US D473,672
US D483,511
US D484,272
Patents pending



ELM — with stationary, fixed-optic lamps



ELM2 — with adjustable lamps

This recall does not include the following light unit models:

- ELM2 SD
- ELM2 LED
- ELM2 WRS

Check the label inside your unit to verify the model number.
Call Acuity Brands Lighting with any questions: 888.615.4501

The two circuit board revisions that are covered by this recall look like this:

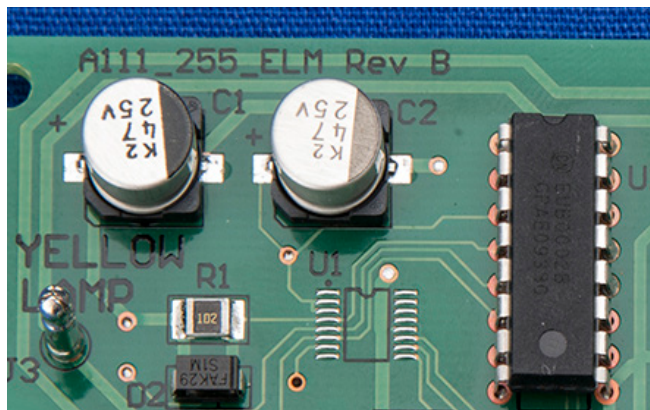

Rev. B

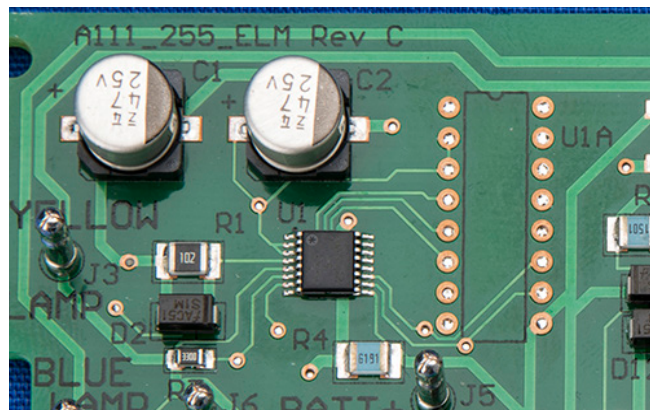

Rev. C

IMPORTANT SAFEGUARDS

1. READ AND FOLLOW ALL SAFETY INSTRUCTIONS.
2. Turn off electricity at fuse or circuit breaker before proceeding.
3. All work should be performed by qualified personnel.
4. For installation and maintenance instructions please go to www.lithonia.com.

CAUTION: BEFORE PROCEEDING WITH THESE STEPS, TURN OFF ELECTRICITY AT FUSE OR CIRCUIT BREAKER LOCATION. READ AND FOLLOW **IMPORTANT SAFEGUARDS** ON FRONT COVER SHEET.

1ST STEP: DETERMINE IF EMERGENCY LIGHTING UNIT IS AN ELM OR ELM2:

Remove the unit from the mounting plate:

A Press both circular snaps at the bottom of the housing. Rotate the housing upward and pull it firmly away from the mounting plate (which will remain mounted on the wall).



Inspect the product catalog number:

B Locate the white sticker inside your unit. Look for "CAT. NO.:" (catalog number).



If the catalog number is one of the following, then your light is not part of the recall:

- ELM2 SD
- ELM2 SD90 NAWT
- ELM2 SD DL
- ELM2 SD USPOM
- ELM2B SD
- ELM2 WRS
- ELM2 LED
- ELM2 LED B
- ELM2 LED NOM
- ELM2 LED WRS

If your catalog number is one of the following, proceed to next step:

- ELM
- ELM CSR
- ELM DL
- ELM2
- ELM2B
- ELM2 DL
- ELM2B DL
- ELM2 NOM
- ELM2 USPOM
- ELM2 220-240V 60Hz

Please skip to the 3rd step, 'Inspection of mounting plate and AC connector'.

2ND STEP: DETERMINE IF THE ELM OR ELM2 CIRCUIT BOARD IS PART OF RECALL AND IDENTIFY DAMAGED CIRCUIT BOARDS:

Inspect the circuit board color:

A If the circuit board color is solid beige (as shown) or beige on one side and green on the other, then your circuit board is **NOT** part of the recall. Proceed to the 3rd step to inspect the mounting plate and AC connector.



Beige circuit boards (i.e., circuit boards that are beige on one or both sides) like the one depicted below are **NOT** part of the recall.

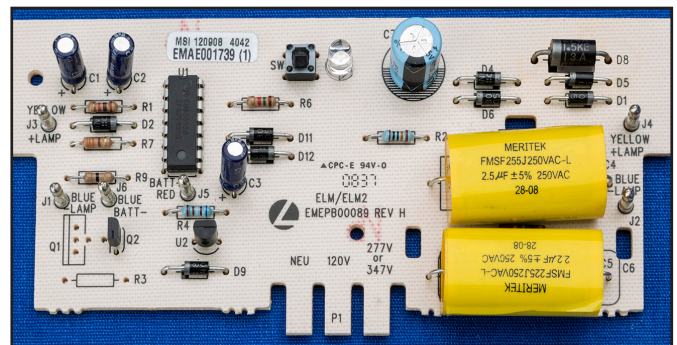

If the circuit board color is solid green on both sides, and you have a catalog number that is listed as part of the recall in step 1B above, then the unit IS included in the recall. Proceed to the next step.

Inspect the circuit board components:

- B** With the circuit board components facing up, inspect the circuit board for damage in the upper right corner. This can be done using a flashlight or by leaving the wires attached and sliding the circuit board out, following the instructions in step 6D (“Remove the circuit board assembly”) and step 7C (“Insert the circuit board assembly”).

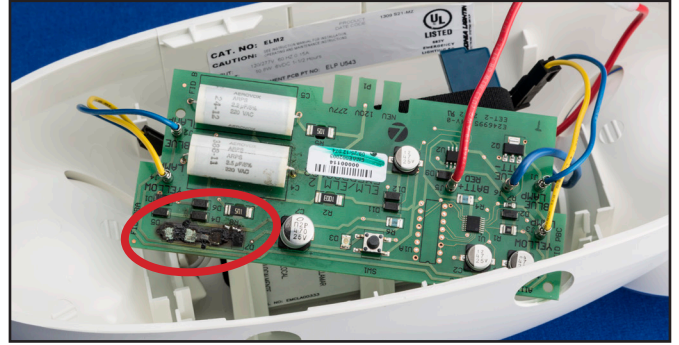

Circuit boards missing one or both of the chips in the upper right corner, as shown in the photos to the right, should not be re-installed. Note: Some circuit boards have a single rectangular chip, and some have two smaller rectangular chips.

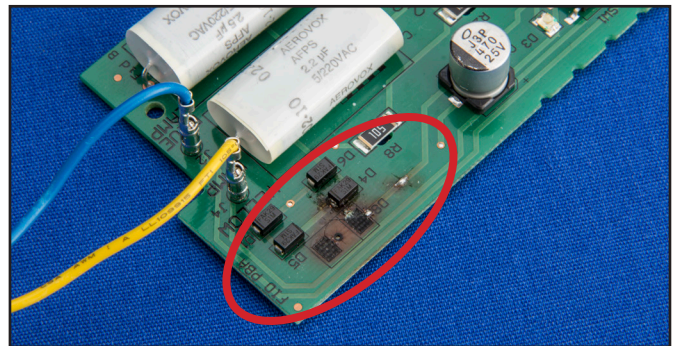
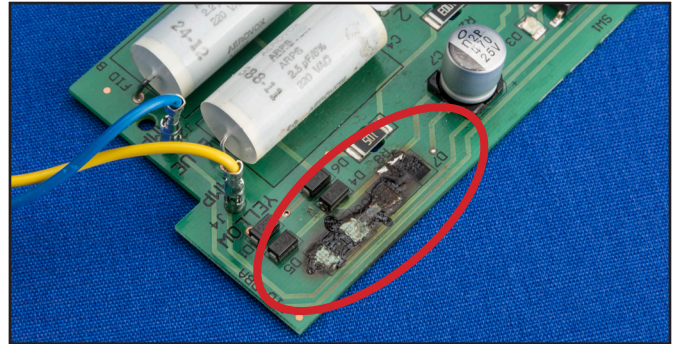

Create an inventory list of affected units:

- C** Repeat steps 1-2 for every emergency lighting unit you believe may be affected. Keep an inventory list of all the affected units. You will use this list to order replacements in the 5th step, but first complete the third and fourth steps.

An inventory sheet is available online at www.lithonia.com, click on the Quantum ELM/ELM2 Recall Information button at the bottom of the page.

Note the location of any units with circuit boards missing one or both of the rectangular chips in the upper right corner of the circuit board, and set aside those units.

3RD STEP: INSPECTION OF MOUNTING PLATE AND AC CONNECTOR:

Inspect the mounting plate snaps:

- A** Inspect all four snaps to ensure that none are damaged. If any damage is present, contact Acuity Brands Lighting at 800.334.8694 for a replacement mounting plate.

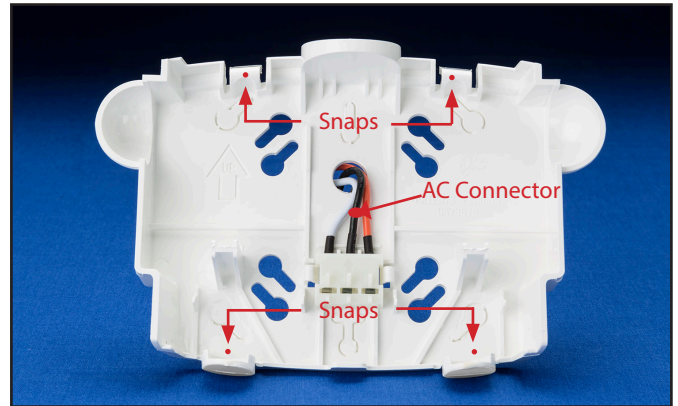

Inspect the AC connector attachment:

- B** Inspect the AC connector to make sure it is securely attached to the mounting plate. If the mounting plate is loose, contact Acuity Brands Lighting at 800.334.8694 for a replacement mounting plate.



Inspect the connector internal contacts:

- C** Inspect the internal contacts for black oxidation/discoloration. If any damage is present, contact Acuity Brands Lighting at 800.334.8694 for a replacement mounting plate.

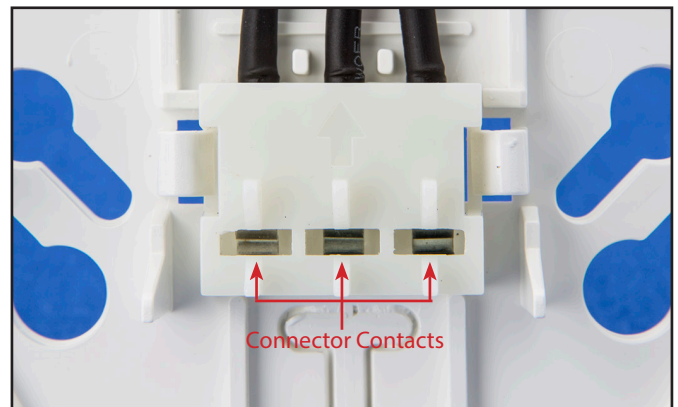

If there is no damage, please proceed to the next step.

4TH STEP: ATTACHING THE UNIT TO THE MOUNTING PLATE:

Unless a unit has a circuit board missing one or both of the rectangular chips in the upper right corner, reattach the unit to the mounting plate until the replacement circuit board is received

Position wires as shown:

- A** Be careful about the placement of the wires within your light unit, to avoid obstruction and/or wire crimping when the unit is remounted. Wire management should match the photo to the right. Battery should be secured firmly by velcro strap. All wires should be positioned in the area of the battery and electronics as shown.



Attach the unit to the mounting plate:

- B** The unit should be affixed to its mounting plate with the snaps aligned, as shown in the photo to the right. Align the holes on the bottom of the housing with the circular snaps at the bottom of the mounting plate, and push the housing directly onto the mounting plate. The two snaps at the bottom, as well as the two hidden snaps at the top, should make an audible snap when fully engaged. Note: Do NOT attempt to mount the light unit to its mounting plate at an angle. Ensure that the unit is mounted squarely to the wall, without leaning, rocking or any gaps.



Inspect top and bottom snaps:

- C** The unit top and bottom should be inspected to ensure that top and bottom snaps are fully engaged and the unit should be flush with the wall.



- D** Apply continuous power to the unit. The test switch/indicator light should illuminate red.

Caution: Battery must be connected to the light unit prior to applying AC power. Damage to the battery will occur if the battery is connected for a prolonged period of time (24 hours or longer) without continuous AC power being provided.

- E** Allow the battery to charge for 48 hours for full charge.

- F** After full battery recharge, press the test switch. Both lampheads should illuminate. If one or more lamps do not illuminate, contact Acuity Brands Lighting at 800.334.8694 to discuss an appropriate solution.

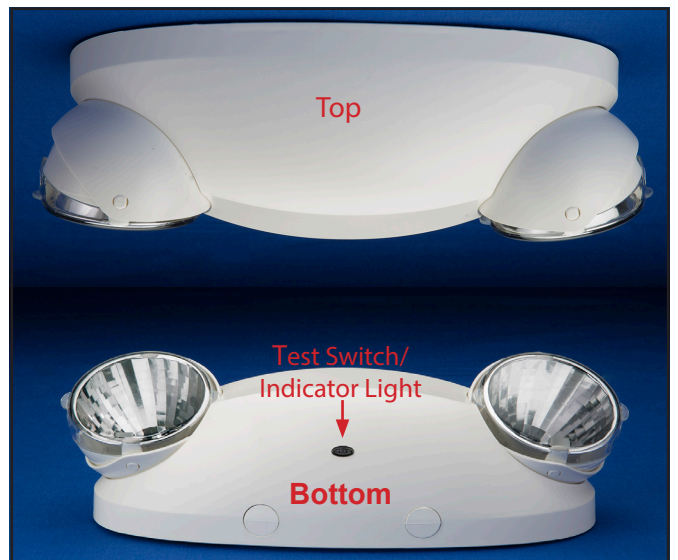

- G** If your light unit is an ELM2 model, aim lampheads to the desired position.

5TH STEP: REQUESTING A NEW CIRCUIT BOARD:

A After determining the total number of recalled circuit boards, then order free replacement boards by going to www.lithonia.com and clicking on "Quantum® ELM/ELM2 Recall Information" at the bottom of the page, or call 888.615.4501.

If any circuit boards are missing one or both of the rectangular chips in the upper right corner, call the recall toll-free number at 888.615.4501 rather than placing your order on-line.

When the replacement boards arrive, proceed to the 6th step.



www.lithonia.com



Recall toll-free number:
888.615.4501

CAUTION: BEFORE PROCEEDING WITH THESE STEPS, TURN OFF ELECTRICITY AT FUSE OR CIRCUIT BREAKER LOCATION. READ AND FOLLOW **IMPORTANT SAFEGUARDS** ON FRONT COVER SHEET.

6TH STEP: REMOVING AND REPLACING RECALLED CIRCUIT BOARD ONCE REPLACEMENT BOARD HAS BEEN RECEIVED:

Note: If your light unit is included in the recall, and you have ordered and received a replacement circuit board, follow these step-by-step removal and replacement instructions.

Dismount all of the affected units:

A Remove the affected emergency lighting units from the wall. Refer to your previously used inventory list for all affected units.

Disconnect the red battery wire connector:

B Disconnect the single pole connector (red battery wire) to disconnect battery power.



Disconnect the lamp connectors (Blue and Yellow wire harnesses):

C ELM2 units only: Disconnect the two blue and yellow wire lamp connectors (they are black clasps). The connectors are released by pressing on the connector lock as shown and gently pulling the connector apart.

ELM units only: These units do NOT have the black connectors, so you will not perform this step yet. Proceed to the step 6D.

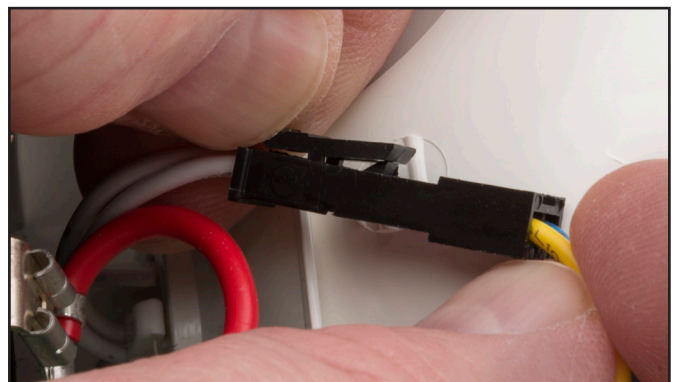

Remove the circuit board assembly:

- D** The circuit board is held in place by two snaps, one at each side of the circuit board. These snaps must be flexed away from the circuit board (as shown) while the board is pulled gently and removed from the housing. It will still be connected to the battery by the thicker blue wire, which will be disconnected in the next step.



Disconnect the blue battery wire connector:

- E** BOTH ELM/ELM2 units: Disconnect the blue battery connector at the BLUE BATT terminal. Use needle-nosed pliers to unplug the battery terminal by wiggling and gently pulling the terminal socket from the terminal pin on the circuit board. Leave the other wire(s) attached to the circuit board in place.

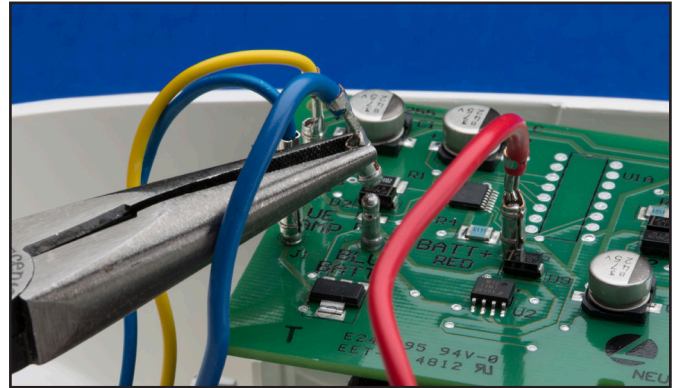

ELM Units only: Now, using needle-nosed pliers disconnect the blue and yellow lamp leads on each side of the circuit board.

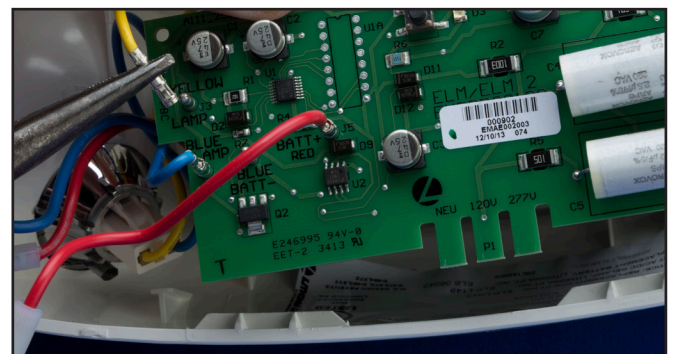
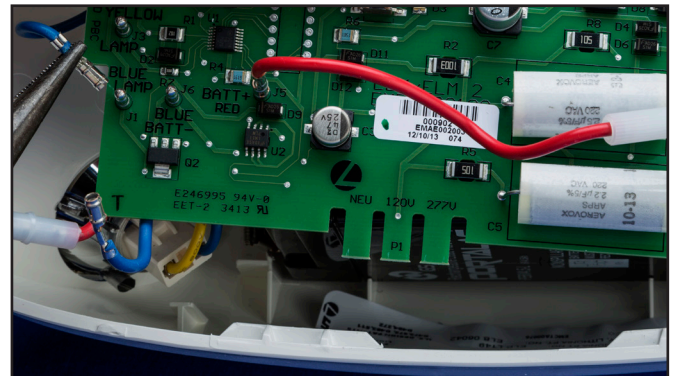

Destroy and discard recalled circuit board:

- F** Destroy recalled circuit boards by breaking the three-pronged edge connectors that extend from the middle of one of the long edges of the board, making the circuit board inoperable. Then discard any remaining wire(s) attached.

NOTE: ELM2 circuit boards will be discarded with yellow, blue and red wires attached as shown in the photo to the right. ELM circuit boards will be discarded with only the red wire attached.

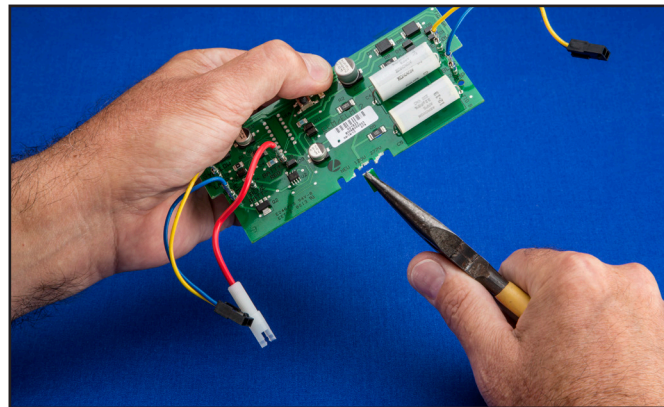

7TH STEP: INSTALLING THE NEW CIRCUIT BOARD:

Connect the blue battery wire connector:

- A** Use needle-nosed pliers to connect the blue wire terminal by plugging it securely onto the circuit board (BAT BLUE) terminal. Replacement boards will be blue.

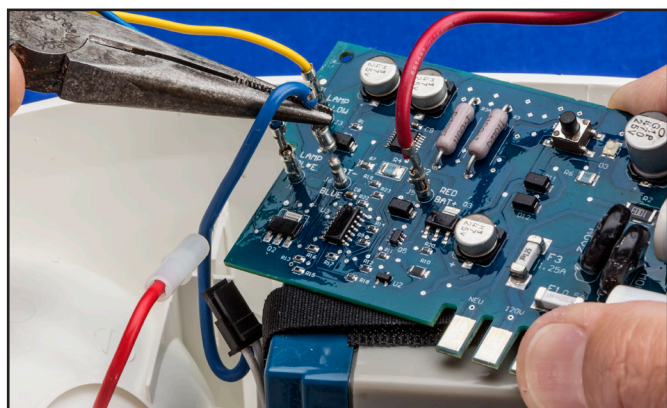

Connect the lamp connectors (Blue and Yellow wire harnesses):

- B** ELM2 units only: Connect the two blue and yellow wire lamp connectors. The connectors should lock together by engagement of the top latch.



ELM units only: Disconnect the blue and yellow lamp leads on each side of the new, blue circuit board and discard them.

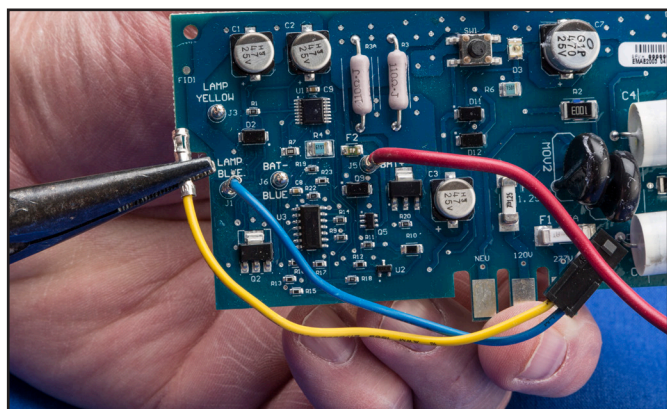

ELM units only (cont.): You have existing blue and yellow wires already in the ELM unit. Snap the existing wire leads to the new circuit board. The positions are labeled: "LAMP YELLOW" and "LAMP BLUE."

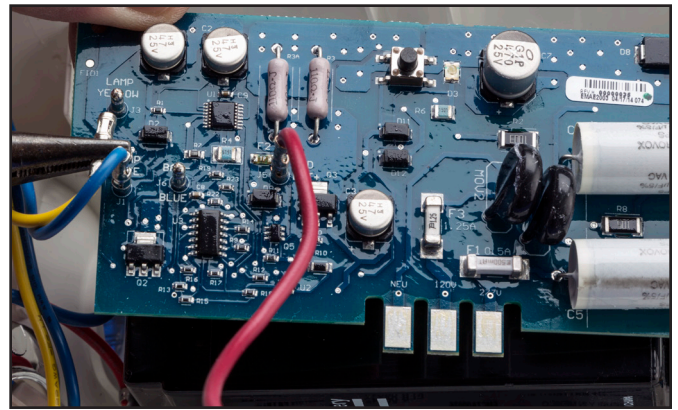

Insert the circuit board assembly:

C The circuit board is held in place by two snaps, one at each side of the circuit board. These snaps must be flexed toward the UL label (as shown). Insert the new circuit board making certain that it slides into the guides at each side.

Circuit board components must be on the side facing the bottom of the fixture, opposite the battery. The three-pronged edge connectors will point toward the open back of the fixture. The snaps should click when the circuit board is fully seated. The board as properly installed is shown in the photo in the 8th step.



Connect the red battery wire connector:

D Connect the single pole connector (red battery wire). Note: This step should be done just before re-attaching the unit to the mounting plate.

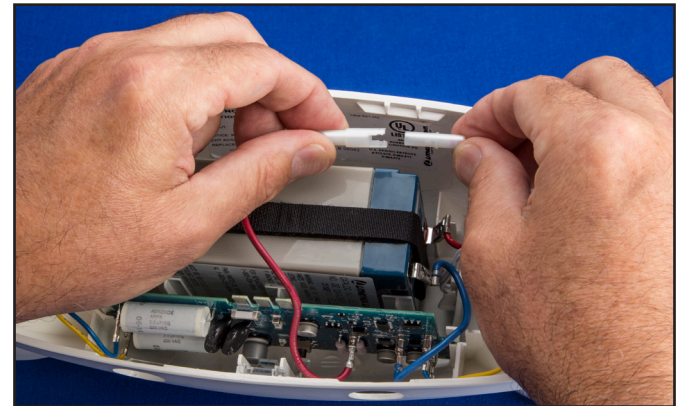

8TH STEP: ATTACHING THE UNIT TO THE MOUNTING PLATE:

Position wires as shown:

A Be careful about the placement of the wires within your light unit, to avoid obstruction and/or wire crimping when the unit is remounted. Wire management should match the photo to the right. Battery should be secured firmly by velcro strap. All wires should be positioned in the area of the battery and electronics as shown.



Attach the unit to the mounting plate:

- B** The unit should be affixed to its mounting plate with the snaps aligned, as shown in the photo to the right. Align the holes on the bottom of the housing with the circular snaps at the bottom of the mounting plate, and push the housing directly onto the mounting plate. The two snaps at the bottom, as well as the two hidden snaps at the top, should make an audible snap when fully engaged. Note: Do **NOT** attempt to mount the light unit to its mounting plate at an angle. Ensure that the unit is mounted squarely to the wall, without leaning, rocking or any gaps.



Inspect top and bottom snaps:

- C** The unit top and bottom should be inspected to ensure that top and bottom snaps are fully engaged and the unit should be flush with the wall.
- D** Apply continuous power to the unit. The test switch/indicator light should illuminate red.
Caution: Battery must be connected to the light unit prior to applying AC power. Damage to the battery will occur if the battery is connected for a prolonged period of time (24 hours or longer) without continuous AC power being provided.

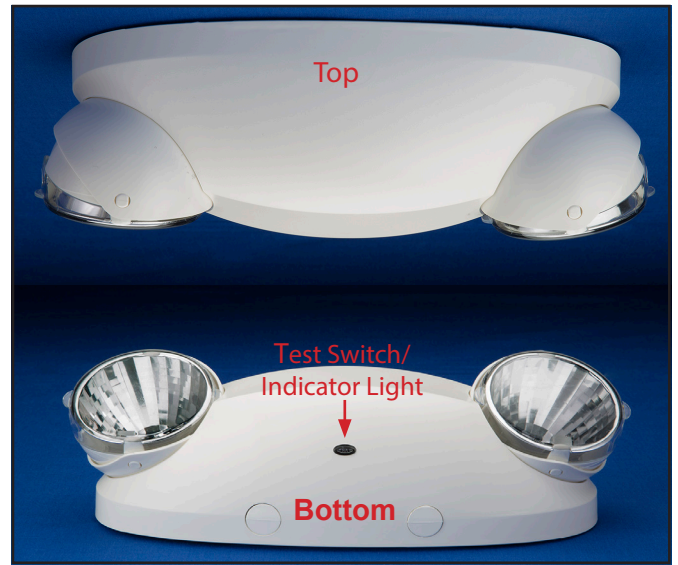

- E** Allow the battery to charge for 48 hours for full charge.
- F** After full battery recharge, press the test switch. Both lampheads should illuminate. If one or more lamps do not illuminate, contact Acuity Brands Lighting at 800.334.8694 to discuss an appropriate solution.
- G** If your light unit is an ELM2 model, aim lampheads to the desired position.

Wiring Diagram, for reference:

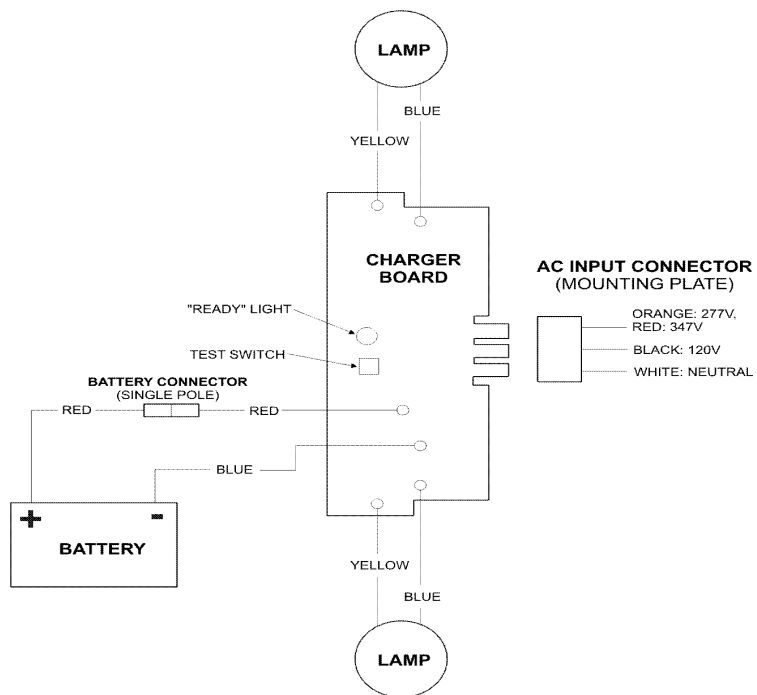

An **Acuity** Brands Company
EMERGENCY LIGHTING SYSTEMS
 TEL: 800-334-8694 Fax: 770-981-8141 www.lithonia.com

Part # EMCSA00852, rev. A